

47 Captive Screws

Restricted access series - M4 and M5 thread size

Features

- Reduces risk of unauthorized access
- Meets UL-1950, IEC 950 and EN-60950
- Hand operation to secure with tool-only removal

Material

- Ferrule:
 - Press-in: Hardened carbon steel, zinc plated, chromate, plus sealer
 - Flare-in and floating: Aluminum, natural
- Knob: Aluminum, natural or black powder coated
- Screw: Hardened carbon steel, zinc plated, chromate, plus sealer



Recess Styles

Slotted

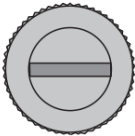

No. 2 Phillips

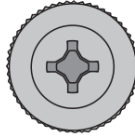

T25 TORX®

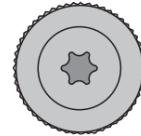

Knob Height and Screw Projection

(Press-in style shown)

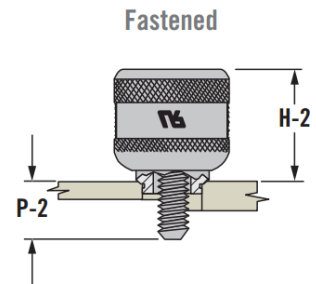
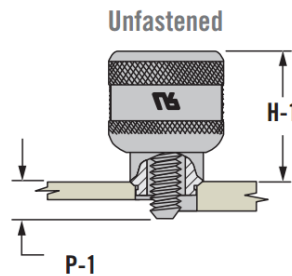
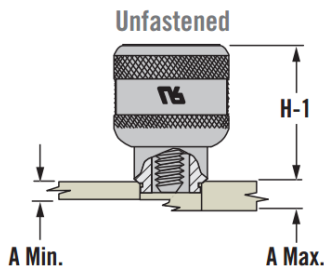

Installation Styles

Press-In Style

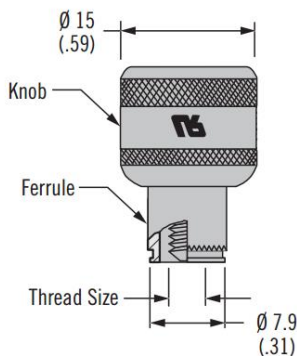

Flare-In Style

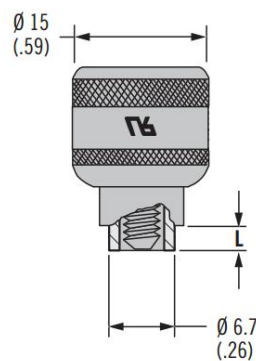

Floating Style

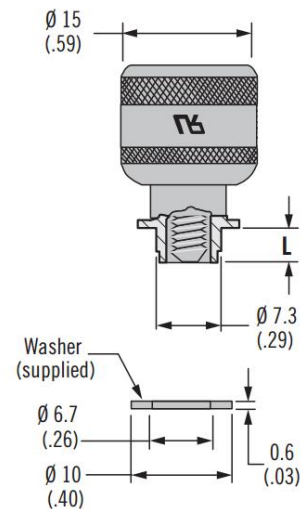

M4 Thread Size

Installation Style	Knob Height		Outer Panel Dimensions		Dimension B*	Flange Length L	Screw Projection Beyond Outer Surface of Panel		Part Number		
	H-1	H-2	A Min.	A Max.			P-1	P-2	Slotted Recess	Phillips Recess	TORX [®] Recess
Press-In Style	18.5 (.73)	14 (.55)	0.9 (.036)	~	~	~	0.7 (.03)	5.6 (.22)	47-90-301-22	47-90-321-22	47-90-341-22
							2.3 (.09)	7.2 (.28)	47-91-301-22	47-91-321-22	47-91-341-22
							3.8 (.15)	8.7 (.34)	47-92-301-22	47-92-321-22	47-92-341-22
							5.4 (.21)	10.3 (.41)	47-93-301-22	47-93-321-22	47-93-341-22
Flare-In Style	18 (.70)	13 (.51)	1.5 (.058)	3.2 (.125)	0.6 (.023)	1.8 (.07)	1.4 (.06)	6.2 (.24)	47-80-302-22	47-80-322-22	47-80-342-22
			3.2 (.125)	4.8 (.188)	1.6 (.062)	3.4 (.14)	3.1 (.12)	7.9 (.31)	47-80-304-22	47-80-324-22	47-80-344-22
			1.5 (.058)	3.2 (.125)	0.6 (.023)	1.8 (.07)	3.1 (.12)	7.9 (.31)	47-81-302-22	47-81-322-22	47-81-342-22
			4.1 (.16)	8.9 (.35)	47-82-302-22	47-82-322-22	47-82-342-22				
			6.1 (.24)	10.9 (.43)	47-83-302-22	47-83-322-22	47-83-342-22				
			2.4 (.09)	7.2 (.28)	47-80-310-22	47-80-330-22	47-80-350-22				
Floating Style	18 (.70)	14 (.55)	0.1 (.001)	0.8 (.031)	2.3 (.09)	3.2 (.13)	3.4 (.13)	8.2 (.32)	47-81-310-22	47-81-330-22	47-81-350-22
			5.4 (.21)	10.2 (.40)	47-82-310-22	47-82-330-22	47-82-350-22				
			2.4 (.09)	7.2 (.22)	47-80-311-22	47-80-331-22	47-80-351-22				
			3.4 (.13)	8.2 (.32)	47-81-311-22	47-81-331-22	47-81-351-22				
			5.4 (.21)	10.2 (.40)	47-82-311-22	47-82-331-22	47-82-351-22				

M5 Thread Size

Press-In Style	18.5 (.73)	14 (.55)	0.9 (.036)	~	~	~	0.7 (.03)	5.6 (.22)	47-90-501-22	47-90-521-22	47-90-541-22
							2.3 (.09)	7.2 (.28)	47-91-501-22	47-91-521-22	47-91-541-22
							3.8 (.15)	8.7 (.34)	47-92-501-22	47-92-521-22	47-92-541-22
							5.4 (.21)	10.3 (.41)	47-93-501-22	47-93-521-22	47-93-541-22
Flare-In Style	18 (.70)	13 (.51)	1.5 (.058)	3.2 (.125)	0.6 (.023)	1.8 (.07)	1.4 (.06)	6.2 (.24)	47-80-502-22	47-80-522-22	47-80-542-22
			3.2 (.125)	4.8 (.188)	1.6 (.062)	3.4 (.14)	3.1 (.12)	7.9 (.31)	47-80-504-22	47-80-524-22	47-80-544-22
			1.5 (.058)	3.2 (.125)	0.6 (.023)	1.8 (.07)	3.1 (.12)	7.9 (.31)	47-81-502-22	47-81-522-22	47-81-542-22
			4.1 (.16)	8.9 (.35)	47-82-502-22	47-82-522-22	47-82-542-22				
			6.1 (.24)	10.9 (.43)	47-83-502-22	47-83-522-22	47-83-542-22				
			3.2 (.125)	4.8 (.188)	1.6 (.062)	3.4 (.14)	4.1 (.16)	8.9 (.35)	47-81-504-22	47-81-524-22	47-81-544-22
Floating Style	18 (.70)	14 (.55)	0.1 (.001)	0.8 (.031)	2.3 (.09)	3.2 (.13)	2.4 (.09)	7.2 (.28)	47-80-510-22	47-80-530-22	47-80-550-22
			3.4 (.13)	8.2 (.32)	47-81-510-22	47-81-530-22	47-81-550-22				
			5.4 (.21)	10.2 (.40)	47-82-510-22	47-82-530-22	47-82-550-22				
			2.4 (.09)	7.2 (.28)	47-80-511-22	47-80-531-22	47-80-551-22				
			3.4 (.13)	8.2 (.32)	47-81-511-22	47-81-531-22	47-81-551-22				
			5.4 (.21)	10.4 (.40)	47-82-511-22	47-82-531-22	47-82-551-22				
			3.4 (.15)	8.2 (.35)	47-80-512-22	47-80-532-22	47-80-552-22				
			5.4 (.21)	10.2 (.40)	47-81-512-22	47-81-532-22	47-81-552-22				

Notes

- All screw part numbers shown in table are for a natural finish
- For black finish minimums may apply

Part numbers in shaded rows (shown in table) are fully retracting in minimum panel thickness



To add a black finish, change the part number from the table as shown:

Change 2 to 6: 47-80-102-22
47-80-102-62

47 Captive Screws

Restricted access series - 6-32 and 10-32 thread size

Features

- Reduces risk of unauthorized access
- Meets UL-1950, IEC 950 and EN-60950
- Hand operation to secure with tool-only removal

Material

- Ferrule:
 - Press-in: Hardened carbon steel, zinc plated, chromate, plus sealer
 - Flare-in and floating: Aluminum, natural
- Knob: Aluminum, natural or black powder coated
- Screw: Hardened carbon steel, zinc plated, chromate, plus sealer



Recess Styles

Slotted

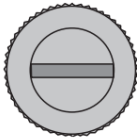

No. 2 Phillips

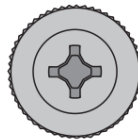

T15 TORX® - 6-32
T25 TORX® - 10-32

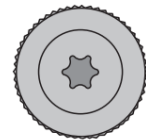

Knob Height and Screw Projection

(Press-in style shown)

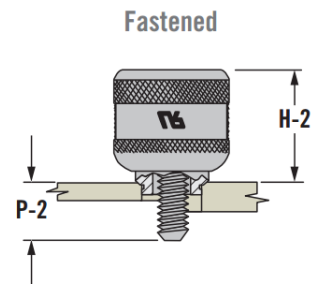
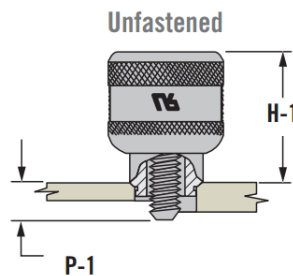
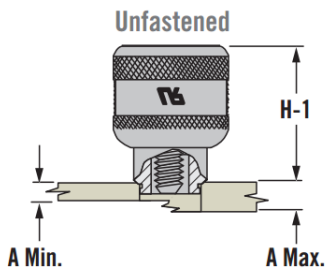

Installation Styles

Press-In Style

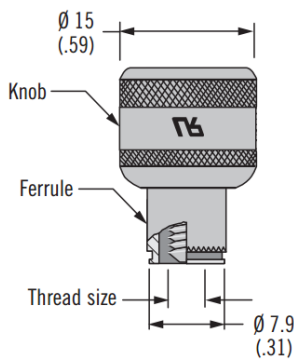

Flare-In Style

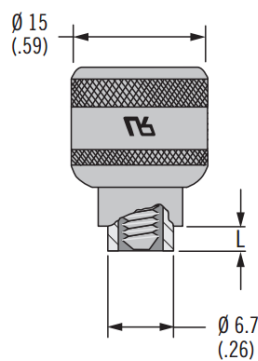

Floating Style

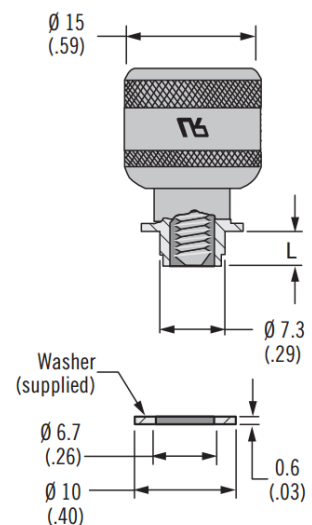

6-32 Thread Size

Installation Style	Knob Height†		Outer Panel Dimensions		Dimension B*	Flange Length L	Screw Projection Beyond Outer Surface Of Panel		Part Number		
	H-1	H-2	A Min.	A Max.			P-1	P-2	Slotted Recess	Phillips Recess	TORX [®] Recess
Press-In Style	18.5 (.73)	14 (.54)	0.9 (.036)	~	~	~	0.5 (.02)	5.3 (.21)	47-60-201-22	47-60-221-22	47-60-241-22
							2.3 (.09)	6.9 (.27)	47-61-201-22	47-61-221-22	47-61-241-22
							3.8 (.15)	8.3 (.33)	47-62-201-22	47-62-221-22	47-62-241-22
							5.3 (.21)	10.1 (.41)	47-63-201-22	47-63-221-22	47-63-241-22
Flare-In Style	18 (.70)	13 (.51)	1.5 (.058)	3.2 (.125)	0.6 (.023)	1.8 (.07)	1.4 (.06)	6.2 (.24)	47-10-202-22	47-10-222-22	47-10-242-22
			3.2 (.125)	4.8 (.189)	1.6 (.062)	3.4 (.14)	3.1 (.12)	7.9 (.31)	47-10-204-22	47-10-224-22	47-10-244-22
			1.5 (.058)	3.2 (.125)	0.6 (.023)	1.8 (.07)	3.1 (.12)	7.9 (.31)	47-11-202-22	47-11-222-22	47-11-242-22
			4.1 (.16)	8.9 (.35)	47-12-202-22	47-12-222-22	47-12-242-22				
			6.1 (.24)	10.9 (.43)	47-13-202-22	47-13-222-22	47-13-242-22				
			4.1 (.16)	8.9 (.35)	47-11-204-22	47-11-224-22	47-11-244-22				
			6.1 (.24)	10.9 (.43)	47-12-204-22	47-12-224-22	47-12-244-22				
			4.1 (.16)	8.9 (.35)	47-11-204-22	47-11-224-22	47-11-244-22				
6.1 (.24)	10.9 (.43)	47-12-204-22	47-12-224-22	47-12-244-22							
Floating Style	18 (.70)	14 (.54)	0.1 (.001)	0.8 (.031)	2.3 (.09)	3.2 (.13)	2.4 (.09)	7.2 (.28)	47-10-210-22	47-10-230-22	47-10-250-22
			3.4 (.13)	8.2 (.32)	47-11-210-22	47-11-230-22	47-11-250-22				
			5.4 (.21)	10.2 (.40)	47-12-210-22	47-12-230-22	47-12-250-22				
			2.4 (.09)	7.2 (.22)	47-10-211-22	47-10-231-22	47-10-251-22				
			3.4 (.13)	8.2 (.32)	47-11-211-22	47-11-231-22	47-11-251-22				
			5.4 (.21)	10.2 (.40)	47-12-211-22	47-12-231-22	47-12-251-22				
			3.4 (.13)	8.2 (.32)	47-10-212-22	47-10-232-22	47-10-252-22				
			5.4 (.21)	10.2 (.40)	47-11-212-22	47-11-232-22	47-11-252-22				

10-32 Thread Size

Press-In Style	18.5 (.73)	14 (.54)	0.9 (.036)	~	~	~	0.7 (.03)	5.6 (.22)	47-60-501-22	47-60-521-22	47-60-541-22
							2.3 (.09)	7.2 (.28)	47-61-501-22	47-61-521-22	47-61-541-22
							3.8 (.15)	8.7 (.34)	47-62-501-22	47-62-521-22	47-62-541-22
							5.4 (.21)	10.3 (.41)	47-63-501-22	47-63-521-22	47-63-541-22
Flare-In Style	18 (.70)	13 (.51)	1.5 (.058)	3.2 (.125)	0.6 (.023)	1.8 (.07)	1.4 (.06)	6.2 (.24)	47-10-502-22	47-10-522-22	47-10-542-22
			3.2 (.125)	4.8 (.189)	1.6 (.062)	3.4 (.14)	3.1 (.12)	7.9 (.31)	47-10-504-22	47-10-524-22	47-10-544-22
			1.5 (.058)	3.2 (.125)	0.6 (.023)	1.8 (.07)	3.1 (.12)	7.9 (.31)	47-11-502-22	47-11-522-22	47-11-542-22
			4.1 (.16)	8.9 (.35)	47-12-502-22	47-12-522-22	47-12-542-22				
			6.1 (.24)	10.9 (.43)	47-13-502-22	47-13-522-22	47-13-542-22				
			4.1 (.16)	8.9 (.35)	47-11-504-22	47-11-524-22	47-11-544-22				
			6.1 (.24)	10.9 (.43)	47-12-504-22	47-12-524-22	47-12-544-22				
			4.1 (.16)	8.9 (.35)	47-11-504-22	47-11-524-22	47-11-544-22				
6.1 (.24)	10.9 (.43)	47-12-504-22	47-12-524-22	47-12-544-22							
Floating Style	18 (.70)	14 (.54)	0.1 (.001)	0.8 (.031)	2.3 (.09)	3.2 (.13)	2.4 (.09)	7.2 (.28)	47-10-510-22	47-10-530-22	47-10-550-22
			3.4 (.13)	8.2 (.32)	47-11-510-22	47-11-530-22	47-11-550-22				
			5.4 (.21)	10.2 (.40)	47-12-510-22	47-12-530-22	47-12-550-22				
			2.4 (.09)	7.2 (.28)	47-10-511-22	47-10-531-22	47-10-551-22				
			3.4 (.13)	8.2 (.32)	47-11-511-22	47-11-531-22	47-11-551-22				
			5.4 (.21)	10.2 (.40)	47-12-511-22	47-12-531-22	47-12-551-22				
			3.4 (.13)	8.2 (.32)	47-10-512-22	47-10-532-22	47-10-552-22				
			5.4 (.21)	10.2 (.40)	47-11-512-22	47-11-532-22	47-11-552-22				

Notes

- All screw part numbers shown in table are for a natural finish
- For black finish minimums may apply

Part numbers in shaded rows (shown in table) are fully retracting in minimum panel thickness



To add a black finish, change the part number from the table as shown:

Change 2 to 6:
 47-80-102-22
 47-80-102-62

47/4C Captive Screws

Panel preparation and installation

Press-In Style

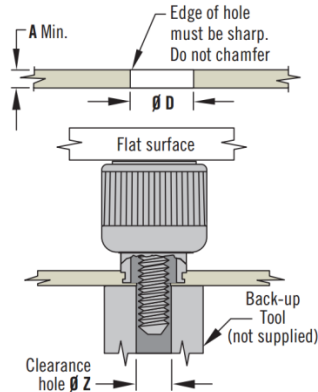

See page 543 for additional installation guidelines

Notes: For use in material hardnesses RB85 or less, such as low carbon steels that are half hard or softer, stainless steels in the annealed condition and aluminum.

Thread Size	ϕD	Clearance Hole ϕZ $+0.2 / +0.008$ $-0.1 / -.004$
M3 or 4-40	5.6 ^{+0.03} _{-0.05} (.219 ^{+0.003} ₋₀)	3.2 (.125)
M3.5 or 6-32	6.4 ^{+0.03} _{-0.05} (.250 ^{+0.003} ₋₀)	3.7 (.146)
M4 or 8-32	8 ⁺⁰ _{-0.08} (.315 ⁺⁰ _{-0.003})	4.4 (.173)
M5 or 10-32	8 ⁺⁰ _{-0.08} (.315 ⁺⁰ _{-0.003})	5.2 (.205)
M6 or 1/4-20	9.5 ^{+0.1} ₋₀ (.375 ^{+0.003} ₋₀)	6.2 (.260)

Installation Notes

1. Prepare panel as shown. Top edge of hole should be sharp.
2. Press captive screw into panel until ferrule is installed as shown

Notes

- Installation closer to the panel edge requires a fixture to constrain the panel edges
- Recommended minimum distance from edge of panel to centerline of hole is $1.5 \times \phi D$

P.C. Board Style

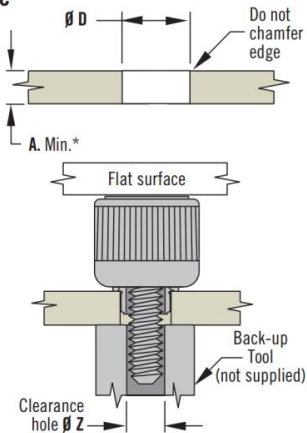

Thread Size	ϕD	Clearance Hole ϕZ $+0.2 / +0.008$ $-0.1 / -.004$
M3 or 4-40	5.6 ^{+0.1} _{-0.05} (.219 ^{+0.004} _{-0.002})	3.2 (.125)
M3.5 or 6-32	6.4 ± 1 (.252 $\pm .004$)	3.7 (.146)

Installation Notes

1. Prepare panel as shown
2. Use pilot lead-in to guide assembly into hole and press knurl into panel until ferrule shoulder contacts surface

Notes

- Strength data based on drilled holes in G-10 P.C. Board
- Pullout force: 360 N
- Side load against unfastened knob: 200 N

Flare-In Style

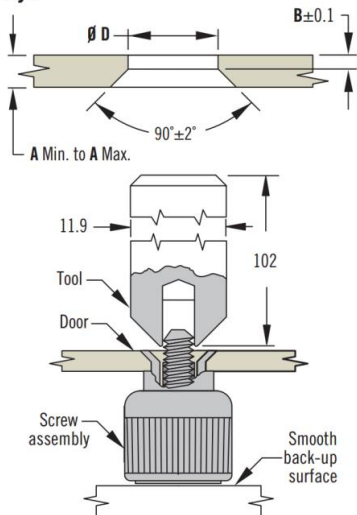

Thread Size	ϕD	Tool Part Number
M3 or 4-40	4.8 ^{+0.08} _{-0.05} (.187 ^{+0.005} ₋₀)	47-104
M3.5 or 6-32	5.4 ^{+0.1} ₋₀ (.213 ^{+0.005} ₋₀)	47-106
M4 or 8-32	6.8 ^{+0.08} _{-0.04} (.266 ^{+0.005} ₋₀)	47-108
10-32	6.8 ^{+0.08} _{-0.04} (.266 ^{+0.005} ₋₀)	47-110
M5	6.8 ^{+0.08} _{-0.04} (.266 ^{+0.005} ₋₀)	47-115
M6 or 1/4-20	8.2 ^{+0.1} ₋₀ (.323 ^{+0.005} ₋₀)	47-125

Installation Notes

1. Prepare panel as shown
2. Install tool in suitable press. Only LIGHT pressure will be required
3. Insert screw assembly into prepared hole in panel
4. Place work under press, center tool over screw thread and flare ferrule into counter-sink in panel. Use LIGHT pressure

Notes

- Installation force: 1,600 N to 2,500 N
- Installation force depends on thread size

Installation Notes

- **Panel preparation 1:**
 - Requires space between inner and outer panels.
 - Specify the fastener for panel thickness A to fall between the range A Min. to A Max.: $gap = B - A$ outer panel thickness
- **Panel preparation 2:**
 - Counter bore the panel (B = Min. panel thickness) to a thickness (A) between the range of A Min. and A Max.
- Minimum bore depth = panel thickness - A Max.
- For gap = \emptyset , panel thickness must be \geq to B value (before counterbore) for the given part number

Notes

- B and A Max. values are provided in the corresponding fastener selection tables for each part number
- If holes are drilled, top edge of hole should be chamfered

Floating Style

Panel preparation 1

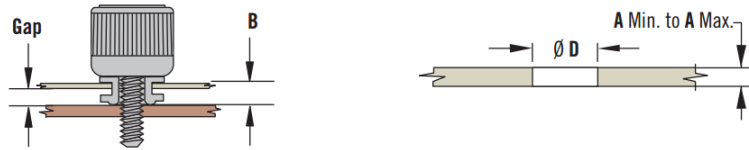

Panel preparation 2

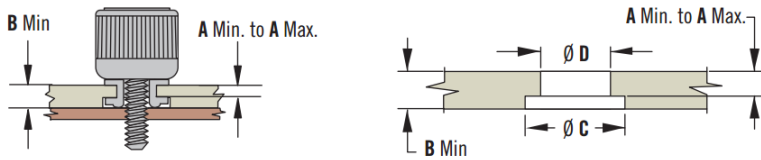

Thread Size	Tool Part Number
M3 or 4-40	47-04
M3.5 or 6-32	47-06
M4 or 8-32	47-08
M5	47-05
10-32	47-10
M6 or 1/4-20	47-25

Thread Size	ϕD <small>+0.008 (+0.003) -0.03 (-0.001)</small>	Counterbore Min. ϕC
M3 or 4-40	6.4 (.250)	9.4 (.375)
M3.5 or 6-32	7.2 (.283)	10.5 (.413)
M4 or 8-32	8.8 (.346)	12 (.469)
M5 or 10-32	8.8 (.346)	12 (.469)
M6 or 1/4-20	10.5 (.413)	13.5 (.531)

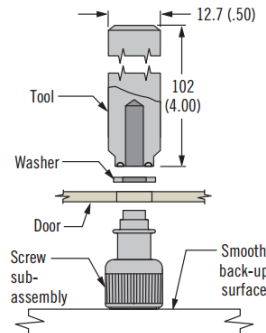

Snap-In Style

Panel preparation 1

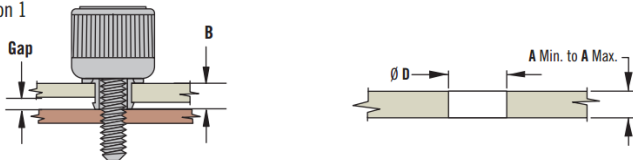

Panel preparation 2

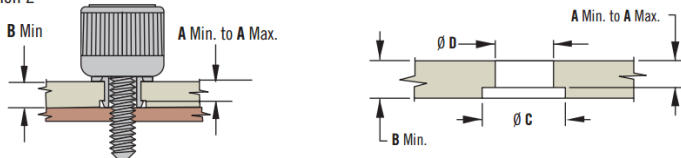

Thread Size	ϕD <small>+0 -0.1 (± .002)</small>	Counterbore Min. ϕC
M3.5 or 6-32	6.4 (.250)	7.5 (.295)
M4 or 8-32	6.4 (.250)	7.5 (.295)
M5 or 10-32	6.4 (.250)	7.5 (.295)

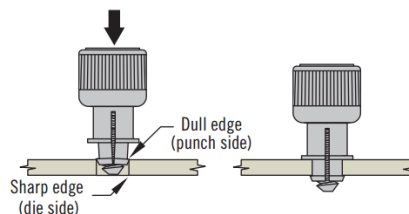

southco®

We are proud to be Southco's authorized distributor of over 20 years